

EC Motor

Series 1

Application

The EVO/ECM-ACU+ allows industry standard 0V to +10V automation signals to adjust and monitor EC Motors. These are fractional horsepower air moving motors featuring an internal microprocessor-based drive. The design provides exceptional efficiency, performance and motor life. The motor may be factory configured to provide constant mass airflow or constant torque over the configured control range.

The ACU+ provides remote adjustment of the motor output from 0 to 100% of the motor's programmed control range. A signal lamp on the control continuously flashes out the flow index¹. Instruments are not required to read the flow index. A 0V - +10V signal connects RPM to the automation control.

Jumpers allow the ACU+ to be configured for 0V to +10V automation signal, +2V to +10V automation signal, and manual/override control. The ACU+ can also be used for stand-alone manual control.

Signal Lamp

The green lamp continuously indicates the flow index. After a pause, the lamp flashes out the tens digit, then the units digit of a number between 1 and 99. Long flashes represent the tens digit, and short flashes represent the units digit. For example, a flow index of 23 flashes two longs, then three shorts. Two extra long flashes indicate a flow index of 0. An extra long flash and ten short flashes indicates a flow index of 100. The lamp flashes the signal that was present when the flash sequence started.

Turning Adjust controls the EC motor to the manually adjusted setting. The manual setting has authority for 15 minutes.

Ordering

EVO/ECM-ACU+	Control without metal plate
EVO/ECM-ACU+ -MP	Control mounted to a single gang ^(US) metal plate.

*Equipment manufacturer:
Please use the model above
as your part number, or in
your description.*



Manual Override

- Temporary local Adjust for air balance.
- Manual control without any 0 - +10V signal.
- Local Default
- Startup mode keeps control in Manual until automation is connected.

When local adjust is turned, Vspd is set by Adjust. Vspd remains at the Adjust value for 15 minutes after the last Adjust movement is detected allowing time to make airflow measurements.

With the "M" jumper in place, Adjust controls the motor when a +0.1-+10V control is not detected. This feature allows the ACU+ to be used as a manual control. And it provides a local default for critical applications by providing a safe operating speed should the +0.1-+10V signal fail.

The ACU+ is provided new with startup mode enabled. The control behaves like the "M" jumper is in place, even if it is not. This allows the mechanical equipment to be tested and used before automation is installed. After automation is installed, the startup mode can be disabled by starting/stopping the motor five times with a +0.1-+10V signal present. The motor start/stop event may be performed by cycling ~24V² power to the control with the control signal above +0.1V, or by raising and lowering the +0.1 - +10V signal with the "P" jumper installed.

¹ Flow Index = percent of the programmed control range.

² ~24V = 24Vac

Jumpers

“P” The “P” jumper provides ON/OFF control by switching the motor’s “GO” control line off when the signal drops below +1 (2mA) volt and on when the signal exceeds +2V (4mA). Adjust turns the motor On/Off with the “P” jumper installed.



Without the jumper, turn ACU+ power On/Off to control motor On/Off.

“M” The “M” jumper enables manual override. In manual override, the fan speed is controlled by the local Adjust when the automation signal is below +0.2V. It controls the motor before automation is installed, or when automation fails. It returns to automation control when the signal is above +0.2V.

Without the “M” jumper, manual override is enabled whenever Adjust is turned. It remains enable for 15 minutes and then returns to automation control.

“S” The “S” jumper reverses Adjust rotation, so adjustment is correct from the component side of the board (sometimes marked “R”).

“Opt” The Opt. space has no function. The space may be used to store an unused jumper.

Specifications

Power NEC Class II or equal
~24V ± 20% 50/60 Hz
2W, 4VA + 1VA/Motor

Control Signal no “P” jumper
0V to +10V = 0%-100% pwm

“P” Jumper
+2 to +10V = 0%-100% pwm
4-20mA = 0%-100% pwm
ON/OFF Control Between
+1V & +2V (2 & 4 mA)

RPM Signal 0V to +10V, 5 mA max.
= 0 to 2,000 RPM in 10 RPM steps

Outputs Go & VSpd +22V ±2V @ 20 mA
2 motor loads
RPM from 1 motor only

Vspd Supports Autoswitch Function

Thermal Stability >0.01%/°F

Operating Environment 0°F to 130 °F (-18°C to 55°C)
10-80% rh

Connections 1/4 Tabs

Signal

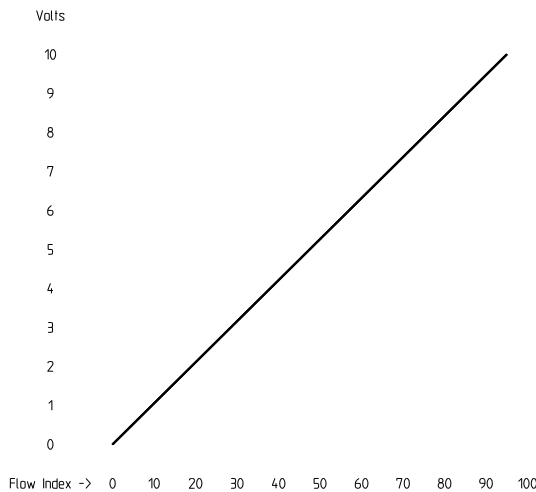

“P” Jumper Out

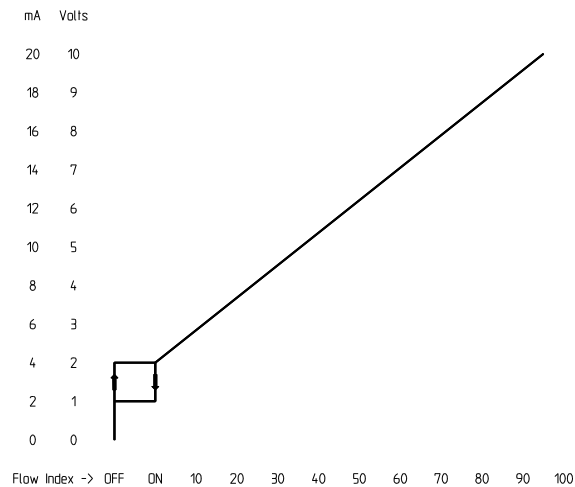

“P” Jumper In

Mounting

Mount the ACU+ inside a metal control cabinet or enclosure. Fasten the mounting posts to an earthed metal surface.

Mount the ACU+ with clearance for the ~24V power wires, automation wires and control cable connector. Mount the control so the Signal and Status lamps are visible. Make Adjust accessible if it is used in your application.

The control may be surface mounted, or reverse mounted so the lamps and Adjust are visible through the enclosure wall.

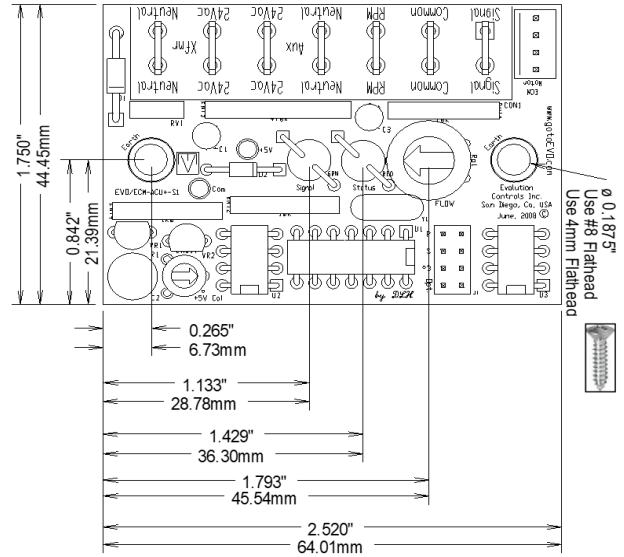

The ACU+-MP is a reverse mounted control on an aluminum single gang ^{US} electrical plate. The plate may be mounted in a single gang electrical box cutout often used to mount a PSC motor speed control. Mount it to a single gang handy box to provide separation from high voltage wiring, or to provide RFI shielding.

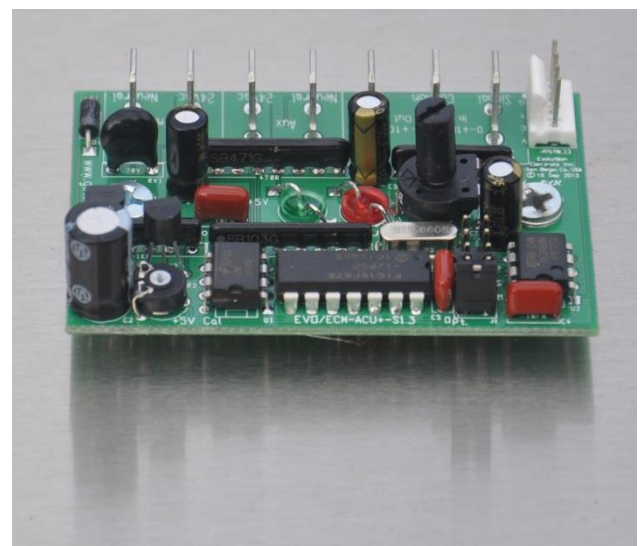

The plate is drilled to accommodate most single gang rectangular outlet trim plates. This plate may be attached to provide a gasketed seal when mounted in a weatherproof box, where door is needed to hide Adjust, or where the ACU+ needs to be wall mounted in an occupied space.

For manual control, use knob EVO/ACC-Knb3.



For surface mount, remove the **shaft** and place it into the Adjust on the component side of the board. A silver or white surface under the LEDs makes them more visible from the component side of the ACU+.

Wiring

Power the EVO/ECM-ACU+ with a ~24V NEC Class II^{USA} power limited transformer³. Observe all code requirements and follow all safety practices regarding low voltage power supplies and circuits to insure a safe, reliable installation.

Some applications may require an isolated power supply or alternative earthing scheme. Follow applicable code requirements and carefully observe all safety practices concerning earthing and safety requirements for low voltage circuits.

Earth one lead of the ~24V side of the power transformer⁴. Connect the earthed lead to the ACU+ Xfmr neutral connection.

Connect the hot lead of the ~24V side of the power transformer to the ACU+ Xfmr ~24V connection.

~24V Aux and Neutral are convenience connections. Up to 20 VA loads may be connected to Aux.

With the "P" jumper out, you may interrupt the Xfmr connection as a means to stop the motor. Most automation controllers will power the ACU+ directly from a ~24V on/off output, eliminating the fan relay. Automation controllers that switch neutral may require a fan relay.

The signal input is single-ended, so the ACU+ internally connects neutral and signal common.

Connect the 0V to +10V control signal to the Signal connection. Connect the control signal common to the Common connection.

The input presents a 21K ohm load to the signal source. Include this resistance when calculating a dropping resistor for 4-20 Ma operation. A 511 ohm 1% resistor⁵ provides a 500 ohm dropping resistance.

Connect to the motor using an EVO/ECM-CBL motor control cable. The control's motor cable connector is small so it may be carefully pulled through an empty 3/4" conduit.

Keep high voltage wiring away from the ACU+ circuitry or wiring. Follow electrical code requirements for separation of high and low voltage wiring and components.

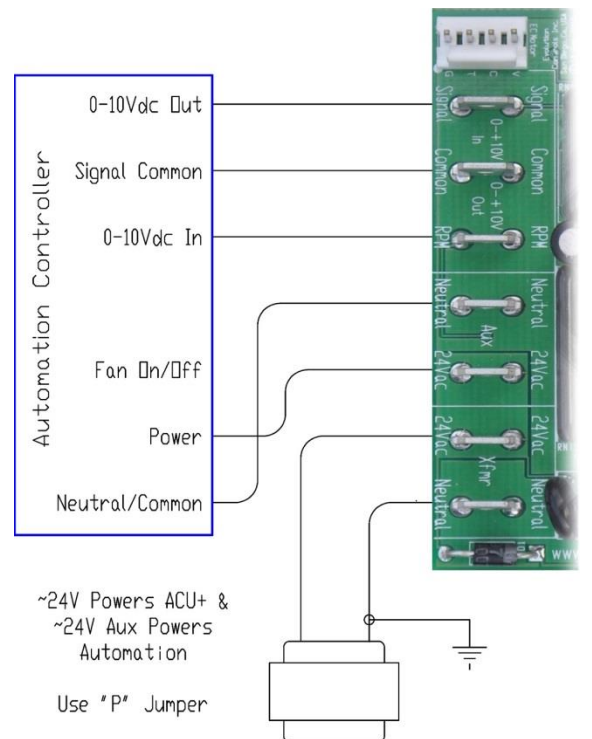
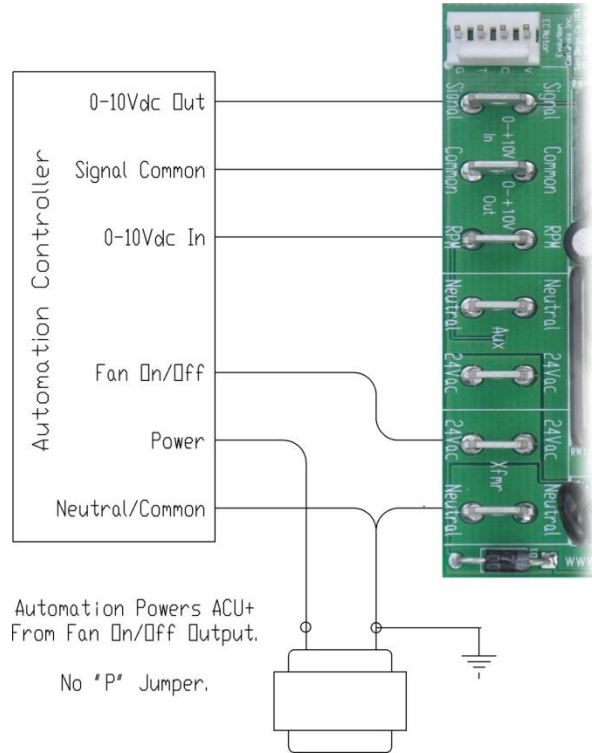
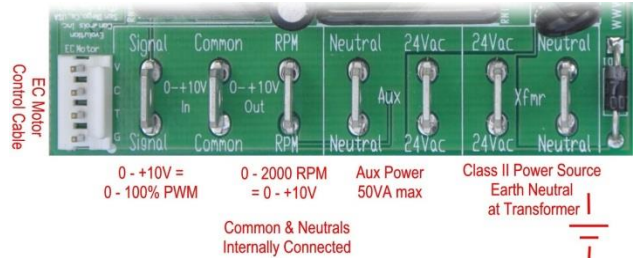

³ See NEC^{USA} 725.41

⁴ NEC^{USA} 250.20.a.

⁵ www.Mouser.com pn. 271-511-RC

During Construction

The equipment manufacturer may have set Adjust to allow heating equipment to operate during construction. If not, Adjust can be set on site to provide a flow to safely operate heating.

Automation Air Balance

If Automation is already installed, air balance can be achieved using automation tools. Please notice that a control signal less than +0.2V may put the ACU+ into manual override. Avoid setting the automation signal to less than +0.2V. **Caution: turning Adjust locks out the automation signal for 15 minutes.** Cycle power for faster lockout removal.

Manual Air Balance

The ACU+ can be manually adjusted before automation is available. The balancer's manual adjustment has authority until automation is connected.

Air Balancer:

1. Use Adjust to set the air flow. This adjustment will have authority for at least 15 minutes.
2. Read the flashing green lamp and record the flow index on the air balance report.

Automation Integrator:

1. Set the Signal to 0V to invoke manual override.
2. Record the RPM on the air balance report.
3. Enter the flow index from the air balance report.
4. Observe the RPM is at or near the RPM observed in step 2.
5. Cycle the motor on/off 5 times.⁶ This clears the manual override function unless the "M" jumper is in place.

Factory Setup

<u>Automation</u>	<u>Manual Adjust</u>
Permanent Manual Override?	Manual Adjust Only?
Y Install the "M" jumper	Y Install the "M" jumper
N Remove the "M" jumper	N Remove the "M" jumper
On/Off control using the +2V to +10V Signal?	On/Off control using the Manual Adjust?
Y Install the "P" jumper	Y Install the "P" jumper
N Remove the "P" jumper	N Remove the "P" jumper
Manual Adjust from the component side?	Manual Adjust from the component side?
Y Install the "S" jumper	Y Install the "S" jumper
N Remove the "S" jumper	N Remove the "S" jumper

⁶ Signal must be greater than +0.1V for 0V to +10V applications.

2 Motor Control

EVO/ECM-MXC2

The EVO/ECM-MXC2 connects one EVO/ECM-ACU+ to control 2 motors. The master control sets the speed of both motors. A second control may be connected to monitor the 2nd motor rpm.

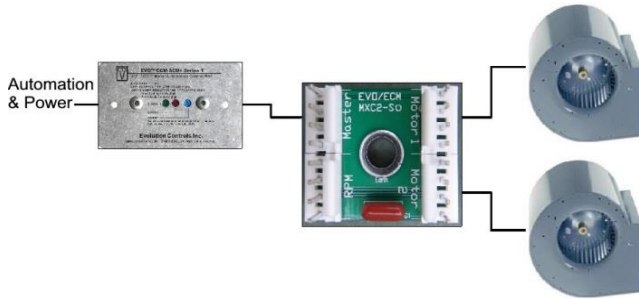

EVO/ECM-4Spd Controls 1 Motor & EVO/ECM-ACU+ Automation RPM Monitor

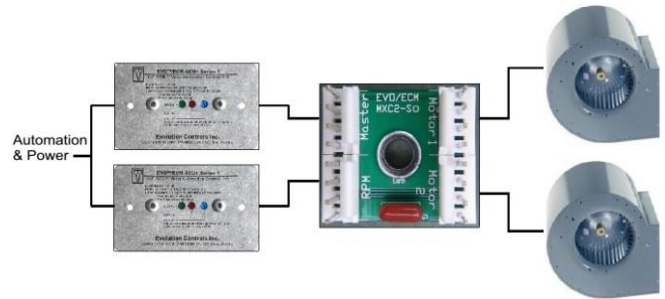

Optional 2nd Control Monitors Motor 2

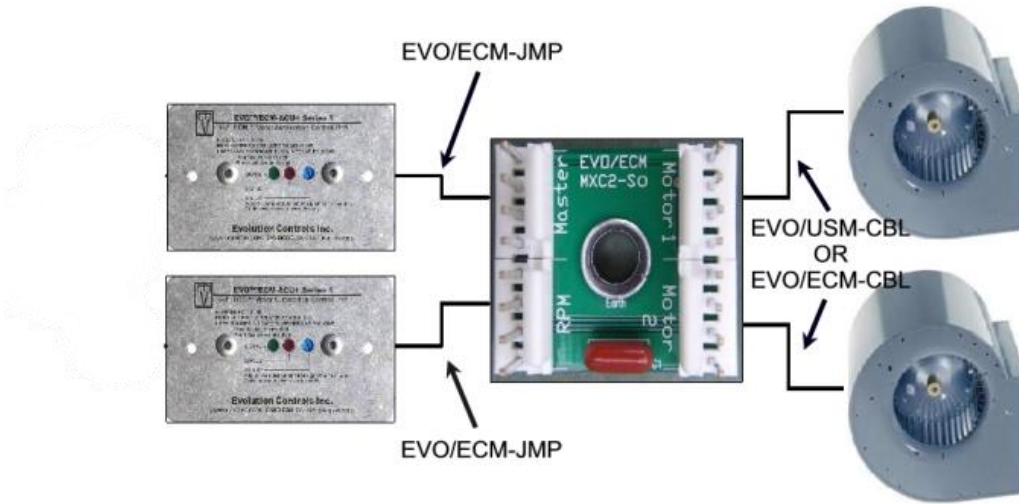

Cabling Details

Parts:

- EVO/ECM-CBL-? Control cable for Genteq 2.3 & 5.0 motor
- EVO/USM-CBL-? Control cable for US Motor Perfect Speed
- EVO/ECM-PIG-? Control cable with unterminated motor end
- EVO/ECM-JMP ? Jumper cable for use with EVO/ECM-MXC2

- EVO/ACC-KNB-0 Standard ACU+ Adjust shaft
- EVO/ACC-KNB-1 Extended ACU+ Adjust shaft
- EVO/ACC-KNB-3 Extended ACU+ Adjust shaft with knob

- 2.54 mm Shunt Standard ACU+ Option header shunt